

# OWNER'S GUIDE

 **VISION**  
FITNESS

**S60**  
COMMERCIAL SUSPENSION  
ELLIPTICAL TRAINER





**C**ongratulations on choosing a VISION FITNESS Suspension Elliptical™ Trainer. You've taken an important step in developing and sustaining an exercise program! Your Suspension Elliptical™ Trainer is a tremendously effective tool for achieving your personal fitness goals. Regular use of your Suspension Elliptical™ Trainer can improve the quality of your life in so many ways...

Here are just a few of the health benefits of aerobic exercise:

- Weight Loss
- A Healthier Heart
- Improved Muscle Tone
- Increased Daily Energy Levels
- Reduced Stress
- Help in Countering Anxiety and Depression
- An Improved Self Image

The key to reaping these benefits is to develop an exercise habit. Your new Suspension Elliptical™ Trainer will help eliminate the obstacles that prevent you from getting in your exercise time. Neither bad weather or darkness will interfere with your workout when you have your Suspension Elliptical™ Trainer in the comfort of your home. This Owner's Guide provides you with basic information on starting an exercise program. A more complete knowledge of your new Suspension Elliptical™ Trainer will assist you in realizing your goal of a healthy lifestyle.

Please contact your authorized VISION FITNESS retailer should service be required. If a question or problem arises which cannot be handled by your VISION FITNESS retailer, please contact us:

VISION FITNESS  
1600 Landmark Drive  
Cottage Grove, WI 53527  
Ph: 1.800.335.4348  
Fax: 1.608.839.8731  
[www.visionfitness.com](http://www.visionfitness.com)

# Table of Contents

## INTRO

SAFETY INSTRUCTIONS .....	4
ASSEMBLY & MOVING .....	6
PLACEMENT, STABILIZING, & POWER .....	7

## CONSOLE

DISPLAY CONSOLE .....	08
DISPLAY CONSOLE DESCRIPTIONS.....	09
BATTERY .....	11
PROGRAM OVERVIEWS .....	12
USING THE PROGRAMS.....	14
USING HEART RATE TRAINING.....	16
USING THE HEART RATE CHEST STRAP.....	17

## GENERAL

PREVENTATIVE MAINTENANCE.....	18
TROUBLESHOOTING.....	19
TRUBLESHOOTING HEART RATE CHEST STRAP.....	20
DEVELOPING A FITNESS PROGRAM...	21
EXERCISE GUIDELINES .....	22
BALANCED FITNESS .....	23

INTRO

CONSOLE

GENERAL



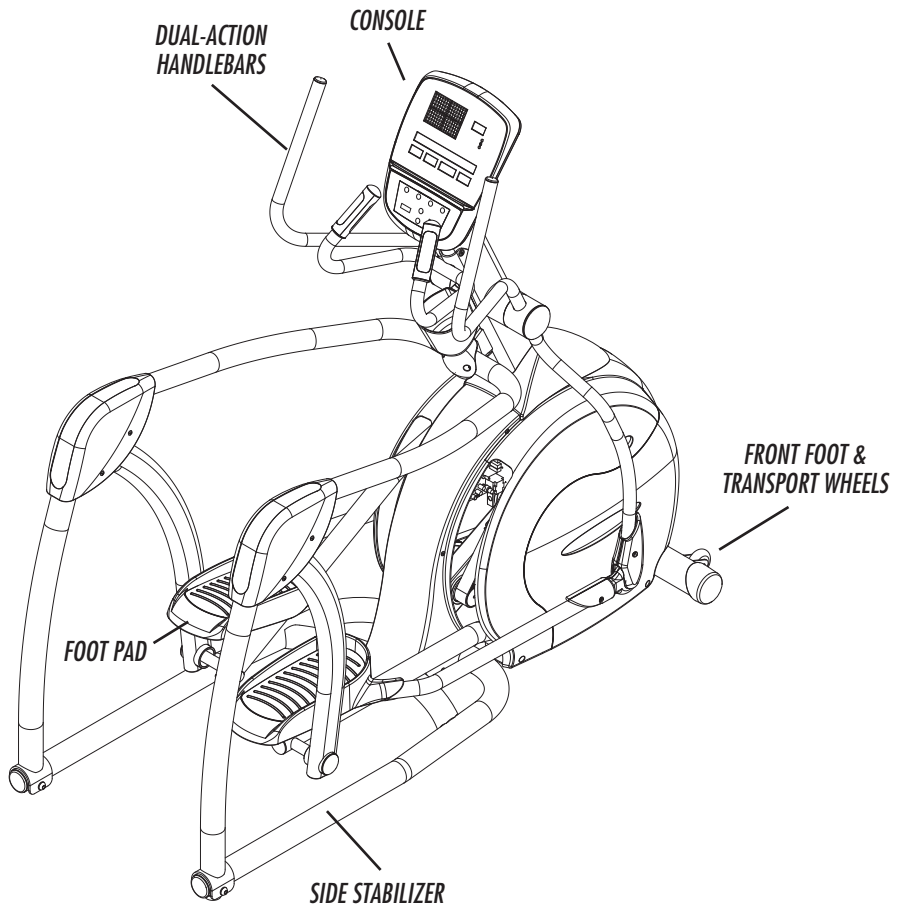

**S 6 0**

COMMERCIAL SUSPENSION ELLIPTICAL TRAINER

## IMPORTANT SAFETY INSTRUCTIONS

### SAVE THESE INSTRUCTIONS

When using an electrical product, basic precautions should always be followed, including the following:

Read all instructions before using this exercise product.

**WARNING!** To reduce the risk of burns, fire, electrical shock or injury to persons:

- Use this exercise product for its intended use as described in this Owner's Guide. Only use attachments recommended by the manufacturer.
- Never drop or insert any object into any opening.
- Do not remove the Suspension Elliptical™ Trainer sidecovers. Service should be performed only by an authorized VISION FITNESS retailer.
- Never operate this Suspension Elliptical™ Trainer if it has a damaged cord or plug, if it is not working properly, or if it has been damaged or immersed in water. Please contact your authorized VISION FITNESS retailer for service.
- Keep the cord away from heated surfaces.
- Do not use outdoors.
- To disconnect, turn the switch to the OFF position, then remove plug from outlet.
- Only use the power cord provided with your VISION FITNESS Suspension Elliptical™ Trainer.
- Never place the power cord under carpeting or place any object on top of the power cord that may pinch and damage it.
- Unplug your Suspension Elliptical™ Trainer when not in use and before moving it.
- The maximum user weight capacity is up to 400 lbs. (182 kg.)

### CHILDREN

- Keep children off your Suspension Elliptical™ Trainer at all times.
- When the Suspension Elliptical™ Trainer is in use, young children and pets should be kept at least 10 feet away.



## OTHER SAFETY TIPS FOR YOUR VISION FITNESS SUSPENSION ELLIPTICAL TRAINER

**CAUTION!** If you experience chest pains, nausea, dizziness or shortness of breath, stop exercising immediately and consult your physician before continuing.

- Do not wear loose clothing that might catch on any part of the Suspension Elliptical™ Trainer.
- Read this Owner's Guide before operating this Suspension Elliptical™ Trainer.

## CLEANING

- Clean only with mild soap and a slightly damp cloth; never use solvents.

## SELF-POWERED FEATURE

The *S60* is a self-powered unit, requiring no external power source. When a user pedals at a speed above 25 revolutions per minute (RPM), the power is generated to allow the unit to function properly.

## ASSEMBLY

It is recommended, when possible, that an authorized VISION FITNESS retailer assemble your Suspension Elliptical™ Trainer. If you have elected to assemble this product yourself, for your safety, please read and follow each of the steps in the enclosed assembly instructions. If you have any questions regarding any component or function of your Suspension Elliptical™ Trainer, contact your retailer.

## MOVING

Your VISION FITNESS Suspension Elliptical™ Trainer has transport wheels included for ease of mobility. To move, firmly grasp the rear of the frame assembly. Carefully lift and roll on the transport wheels.

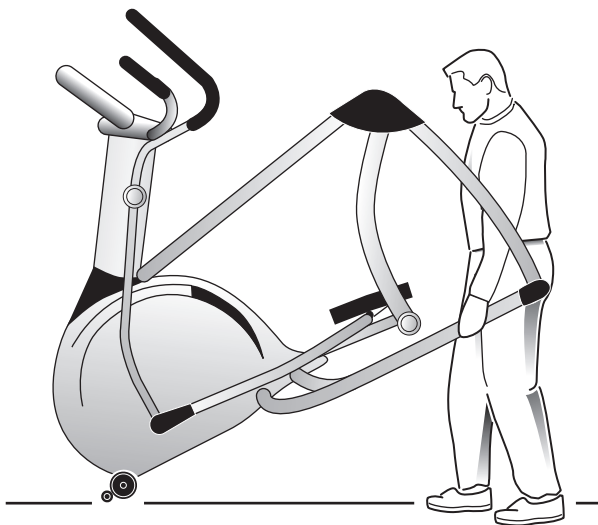

**CAUTION:** Our Suspension Elliptical™ Trainers are well-built and heavy, weighing up to 340 pounds! Use care and additional help if necessary.

## STABILIZING THE SUSPENSION ELLIPTICAL TRAINER

After positioning the Suspension Elliptical™ Trainer in its intended location, check the unit's stability. Rocking or wobbling indicates that your Suspension Elliptical™ Trainer needs to be leveled. Determine which leveler is not resting completely on the floor. Loosen the nut at the base of the leveler to allow the leveler to rotate. Now rotate the leveler to the left or right until the Suspension Elliptical™ Trainer is stable. Lock the adjustment by tightening the nut against the support tube.

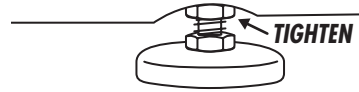
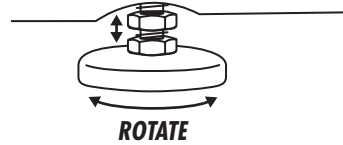
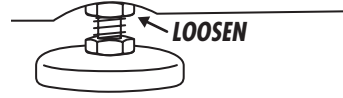

## DISPLAY CONSOLE

### DISPLAY CONSOLE OVERVIEW

The computerized display allows the user to select a workout that meets their desired fitness goals. It also allows the user to monitor the progress and feedback of each workout so they can track improvements in overall fitness over time.

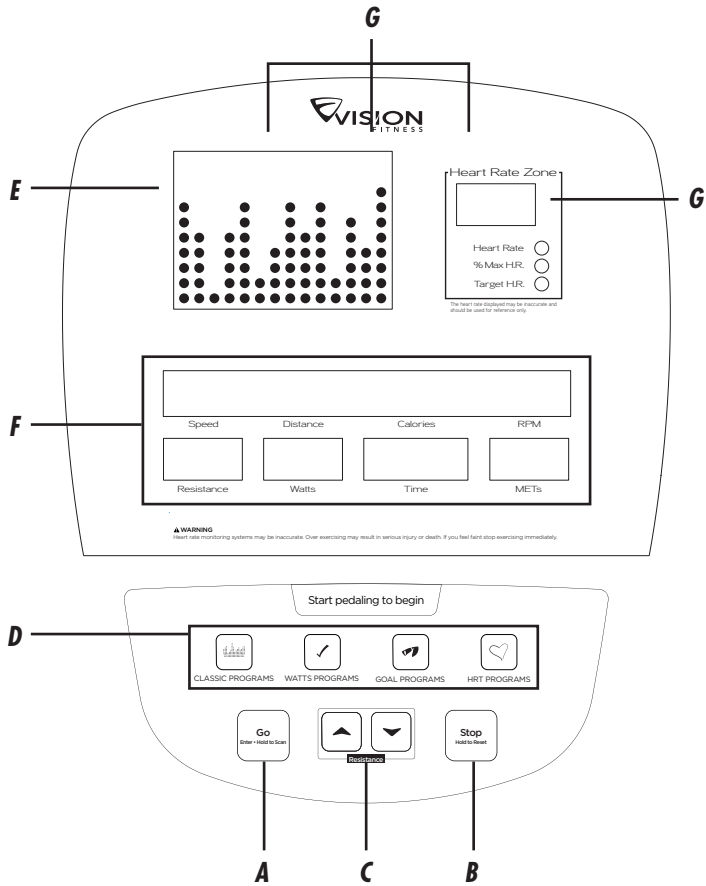

## DISPLAY CONSOLE DESCRIPTIONS

### A. GO/ENTER/HOLD TO SCAN

Press the GO key to begin a MANUAL workout immediately without having to set individual information. When the program begins, you have the ability to adjust resistance levels with the ARROW keys. Feedback information will be calculated using default settings.

**ENTER:** This key is used after entering each piece of information in setup such as age, weight, or level.

**HOLD TO SCAN:** If you need to change the display of heart rate, you can do so by holding down the GO button for three seconds, the HEART RATE ZONE window will display HEART RATE, % MAX. HEART H.R., TARGET H.R. in sequence in HRT PROGRAMS.

### B. STOP/HOLD TO RESET

**STOP:** If you need to STOP your program during the workout, press the STOP key will STOP the program.

**RESET:** If you need to RESET the console during your workout, you can do so by holding down the GO button for three seconds or until the display resets.

### C. ARROW BUTTONS

These keys are used to change values in setup mode prior to your workout. During your workout, they are used to change workout levels. In HRT® programs, they are used to change your target heart rate.

### D. PROGRAM BUTTONS

These keys provide quick access to your favorite workouts. Press the arrow keys to select one of multiple workouts.

## DISPLAY CONSOLE DESCRIPTIONS (continued)

### E. PROFILE DISPLAY

This window provides a dot matrix profile of the workout segments you are about to complete, as well as those you have already completed, and the level of resistance for each segment.

### F. MESSAGE/FEEDBACK WINDOWS

These windows provide step-by-step instructions in the setup mode, instructions, feedback and motivational messages during your workout.

#### FEEDBACK:

During your workout, these windows display exercise feedback about your workout, including:

**SPEED:** the pedaling speed in miles or kilometers per hour.

**DISTANCE:** the total distance traveled in miles or kilometers since the start of your workout.

**CALORIES:** an estimate of calories burned since the beginning of the workout.

**RPM:** the pedal rate or Revolutions Per Minute (RPM).

**RESISTANCE:** the current resistance level of your workout.

**WATTS:** a measurement of workload; one watt is equal to six kilogram-meters per minute.

**TIME:** the time elapsed or the time remaining in your workout.

**METS:** a measurement of oxygen consumption; one MET equals the approximate amount of oxygen consumed per minute by a person at rest.

**NOTE:** At the end of your workout, the totals will be displayed as averages of your total workout time. The only exceptions are distance and calories, which are program totals.

### G. HEART RATE/HRT FEEDBACK WINDOW

This window provides feedback on your current heart rate and the percent of your predicted maximum heart rate (% Heart Rate). It also includes your target heart rate when using one of the HRT® programs.

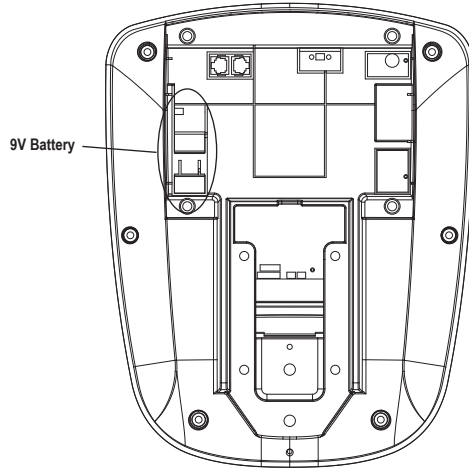

**CONSOLE**

**BATTERY:** Your console is equipped with a 9V battery to maintain workout information.

## PROGRAM OVERVIEWS



## CLASSICS

**MANUAL** is a user-controlled program in which the resistance remains at a set level unless you decide to change it.

**INTERVAL** is an efficient workout that strengthens your cardiovascular system by alternating work intervals and recovery intervals. Be sure to challenge yourself with intense work intervals.

**FAT BURN** is a program designed to target your stored body fat. This program is generally used at a slightly lower resistance level but runs for longer durations than other programs.

**RANDOM** is a program that will give you a different workout every time you workout. The resistance levels will change randomly, providing a challenging workout.

## WATTS PROGRAMS

**CONSTANT WATTS** allows you to set your target WATT output (energy output). The resistance will change automatically to keep you at your target WATTS.

**INTERVAL WATTS** allows you to choose a high WATTS value and a low WATTS value. The interval program will switch between High and Low WATTS values, making for a very intense and effective workout.

**HILL WATTS** lets you choose four WATTS levels. Each WATTS level will change at 1 minute intervals and repeat until your preset workout time is over. Perfect for a challenging workout.





## GOAL PROGRAMS

**TIME GOAL** allows you to set your target workout time. This program can help users to manage the time when they workout.

**DISTANCE GOAL** allows you to choose the workout distance. This program can help users to do self-challenge.

**CALORIES GOAL** allows you to set the calories you want to consume during workout. This program can help the users to control the calories.



## HRT® PROGRAMS

**HRT INTERVAL** this program is designed to increase your cardiovascular fitness capacity. The user must grasp the hand pulse sensors or wear a telemetric heart rate chest strap during use.

**HRT WEIGHT LOSS** is a lower intensity workout that will help your body burn a higher percentage of calories from your body's fat reserves. The user must grasp the hand pulse sensors or wear a telemetric heart rate chest strap during use.

## USING THE PROGRAMS

### SELECTING EASY START

The easiest way to begin exercising is to simply press the GO key. You will begin exercising in a MANUAL resistance program in which you can change the resistance levels to meet your goals. Current default settings will be used to determine exercise feedback.

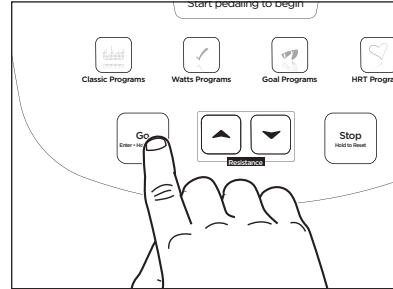

### SELECTING A PROGRAM

Each program has its own program button. Some program buttons have multiple programs. Press the key of the program you would like to use.

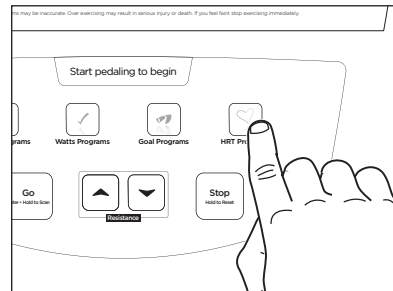

### ENTERING AGE

When prompted by the message center to enter your age, use the UP ▲ arrow or DOWN ▼ arrow to adjust displayed age to the correct value. This information is necessary for the HRT® programs and will affect your "% Heart Rate" feedback.

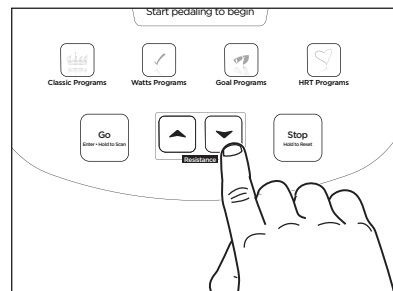

### ENTERING TIME

When prompted by the message center to enter a time, use the UP ▲ arrow and DOWN ▼ arrow to adjust the displayed exercise time to a desired value.

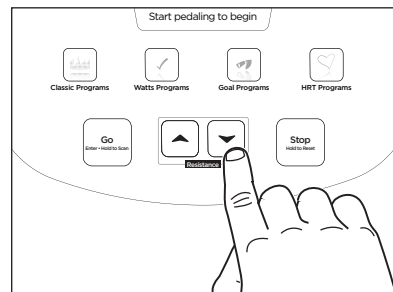

### ENTERING RESISTANCE

When prompted by the message center to enter level, use the UP ▲ arrow and DOWN ▼ arrow to adjust the displayed resistance level. There are 25 levels of resistance to choose from in each program. The maximum resistance level varies by program.

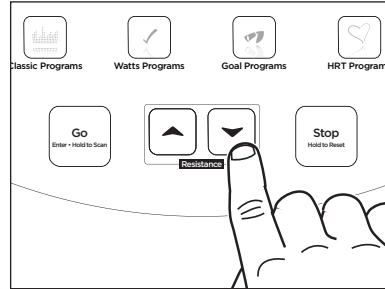

### ENTERING WEIGHT

When prompted by the message center to enter weight, use the UP ▲ arrow and DOWN ▼ arrow to adjust the displayed weight to equal your current body weight. This information is necessary to give accurate exercise feedback for calorie and MET calculations.

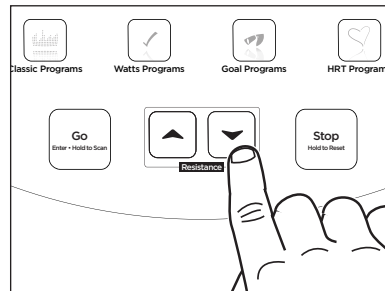

This is a elliptical that the braking system is adjustable. The training speed and resistance setting below that are used in the test for reference.

RPM	LEVEL	DISPLAY (WATT)
50	4	60
	5	68
	9	102
60	12	155
	16	195
70	17	237
	20	273

The WATTS programs will ask you to set the desired WATT level instead of resistance levels. The WATT level will range from 40 to 250 in increments of five.

The HRT programs will set your target heart rate in the place of resistance level. The console will display your target heart rate and give you the opportunity to adjust this value if you wish.

## USING HEART RATE TRAINING

### WHAT IS HEART RATE TRAINING?

Heart Rate Training means exercising at an intensity that keeps you in your ideal heart rate zone. Your personal heart rate training zone depends on your fitness goal, such as weight loss, cardiovascular endurance, or strength building. VISION FITNESS HRT® programs are set up to keep you at an ideal heart rate based on your fitness goal. These programs automatically adjust resistance based on your heart rate readings.

The X60 console features two programs (HRT Weight Loss, HRT Interval) that offer the benefits of Heart Rate Training. Refer to Page 19 for more details on these programs.

### HAND PULSE HEART RATE SENSORS

The Contact Hand Pulse Sensors are included on each product to monitor your heart rate. To use, grasp the sensors with a comfortable grip during your workout. The console will display your heart rate. Although your signal will be displayed immediately, it may take the system a few seconds to zero in on your actual heart rate.

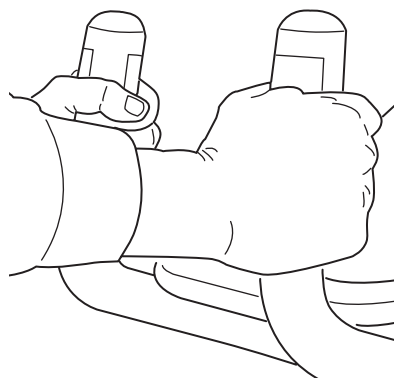

**NOTE:** The Contact Hand Pulse Sensors will work for the HRT® programs, but it is recommended to use the telemetric chest strap for an uninterrupted signal and ease of use.

**WARNING:** Heart rate monitoring systems may be inaccurate. Over exercising may result in serious injury or death. If you feel faint stop exercising immediately

## TELEMETRIC HEART RATE CHEST STRAP

The wireless Telemetric Chest Strap uses a pair of electrodes on the underside of the strap to send your heart rate signal to the console. Prior to wearing the chest strap, moisten the two rubber electrode pads with several drops of water. These electrodes must remain wet to provide an accurate signal. We advise using the chest strap against your skin, but it also functions through a thin layer of wet clothing.

**NOTE:** Heart Rate Chest Strap is optional, not include in the box

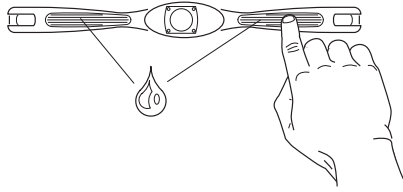

## STRAP PLACEMENT

Center the transmitter strap just below the breast or pectoral muscles, directly over your sternum with the logo facing out. Adjust the elastic strap so it is snug but comfortable enough for proper breathing.

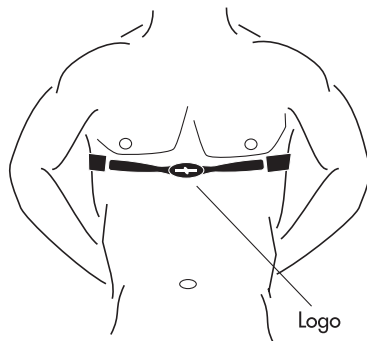

## SERVICE AND TROUBLESHOOTING

### PREVENTATIVE MAINTENANCE TIPS

- Locate Suspension Elliptical™ Trainer in a cool, dry place.
- Make sure all bolts and fasteners are kept tight.
- Keep the display console free from fingerprints and salt build-up caused by sweat.
- Use a cotton cloth with water and a mild cleaning product to clean the Suspension Elliptical™ Trainer. Other fabrics, including paper towels, may scratch the surface. Do not use ammonia or acid-based cleaners.
- Clean the exterior of the machine thoroughly on a regular basis.

### PREVENTATIVE MAINTENANCE SCHEDULE

Follow the schedule below to ensure proper operation of the product.

<b>ITEM</b>	<b>DAILY</b>	<b>MONTHLY</b>	<b>BI-ANNUALLY</b>	<b>ANNUALLY</b>
DISPLAY CONSOLE		CLEAN		
ALL BOLTS AND HARDWARE			INSPECT	
FRAME		CLEAN		INSPECT
HANDLEBARS		CLEAN		
PLASTIC COVERS		CLEAN		
FOOTPLATES		CLEAN		
POWER CORD				INSPECT

## TROUBLESHOOTING

Our Suspension Elliptical™ Trainers are designed to be reliable and easy to use. If, however, you have a problem, these troubleshooting steps may reveal the cause.

**PROBLEM:** The console does not light up.

**SOLUTION:** Check to make sure the power switch located on the backside of the console is turned on.

**SOLUTION:** Make sure the power cord is plugged into the base of the Suspension Elliptical™ Trainer, and the power switch located near the plug is on.

**SOLUTION:** Make sure the wire harness is plugged into the back of the console.

**PROBLEM:** You feel a thump or hitch in the stride motion.

**SOLUTION:** Check assembly and tightness of all hardware.

**SOLUTION:** Check the bolts and the bracket under the footplate.

**NOTE:** If the above steps fail to remedy the problem, discontinue use, turn the power off and contact your retailer.

## TROUBLESHOOTING YOUR HEART RATE MONITOR CHEST STRAP

**PROBLEM:** No pulse reading appears.

**SOLUTION:** There may be a poor connection between the contact pads and skin. Remoisten the contact pads.

**SOLUTION:** Transmitter is not properly positioned; reposition the chest strap.

**SOLUTION:** Verify that the distance between the transmitter and receiver is not beyond the recommended range of 36 inches.

**PROBLEM:** There is an erratic pulse rate.

**SOLUTION:** Chest strap is too loose; readjust according to directions.

**NOTE:** It is possible that heart rate monitors will not function properly on some people for a variety of reasons. It may be necessary to experiment with the fit and position of the chest strap. Outside interference sources such as computers, motors, electric dog fences, home security systems, remote controls, CD players, fluorescent lights, etc., may cause problems for heart rate monitors.



## DEVELOPING A FITNESS PROGRAM

By purchasing this piece of VISION FITNESS exercise equipment, you have made a commitment to exercise and now have the convenience of exercising in your own home. Your new equipment offers the flexibility to exercise at whatever time suits you best. It will be easier to maintain a consistent exercise program that will help you achieve your fitness goals.

## ACHIEVING YOUR FITNESS GOALS

An important step in developing a long-term fitness program is to determine your goals. Is your primary goal to lose weight? Improve muscle tone? Relieve stress? Prepare for the spring racing schedule? Knowing what your goals are will help you develop a more successful exercise program. If possible, try to define your personal goals in precise, measurable terms over specific periods of time. Examples of these goals might include:

- Decrease your waistline by two inches over the next two months.
- Run the local 5K race this summer.
- Get 30 minutes of cardiovascular exercise at least five days per week.
- Improve your race time by two minutes over the next year.
- Move from walking a mile to jogging a mile within the next three months.

The more specific the goal, the easier it will be to track your progress. If your goals are long-term, divide them into monthly and weekly segments. Long-term goals can lose some of the motivational benefits. Short-term goals are easier to achieve and will allow you to see the progress you are making. Every time you reach a goal, it is important to set a new goal. This will lead to a healthier lifestyle and will provide the motivation that you will need to move forward.

## TRACK YOUR PROGRESS

Now that you have set your exercise goals, it is time to write them down and make an exercise schedule that will help you achieve them. By keeping a fitness diary, you will stay motivated and know where you are in terms of reaching your goals. As time goes on, you will be able to look back with pride to see how far you've come. For your convenience, we have included exercise log sheets in the wellness tools section of our website at [www.visionfitness.com](http://www.visionfitness.com).

## EXERCISE GUIDELINES

### EXERCISE DURATION

A common question asked is, “how much exercise do I need?” We recommend following the guidelines set up by the American College of Sports Medicine (ACSM) for healthy aerobic activity.

- Exercise three to five days per week.
- Warm up for five to 10 minutes before aerobic activity.
- Maintain your exercise activity for 30 to 45 minutes.
- Gradually decrease the intensity of your workout, then stretch to cool down during the last five to 10 minutes.

If weight loss is a major goal, participate in your aerobic activity at least 30 minutes for five days each week.

### EXERCISE INTENSITY

The next question asked is, “how hard do I need to work out?” To reap the most cardiovascular benefits from your workout, it is necessary to exercise within a recommended intensity range. We recommend monitoring your exercise heart rate to measure exercise intensity.

## BALANCED FITNESS

While cardiovascular exercise has been the primary method of fitness for many programs over the years, it should not be the only method. Strength Training and Flexibility Training have become more popular as exercise has developed. Incorporating Strength and Flexibility Training into your current exercise program will give you the balance you need to improve your athletic performance, reduce susceptibility to injury, increase metabolic rate, increase bone density, and reach your goals faster.

## STRENGTH TRAINING

Strength Training was once known as an activity performed by young males only. That has changed with the advances in scientific research on Strength Training over the last 20 years or so. Research has proven that, after age 30, we begin to lose muscle mass if we do not incorporate Strength Training into our exercise program. With this decrease in muscle mass, our ability to burn calories decreases, our physical ability to do work decreases and our susceptibility to injuries increases. The good news is that, with a proper Strength Training program, we can maintain or even build muscle as we age. A proper Strength Training program will work the muscle groups of the upper and lower body. There are now many options available for Strength Training including: yoga, Pilates, selectorized machines, free weights, stability balls or medicine balls, exercise tubing and body weight exercises, just to name a few.

Recommendations for a minimum Strength Training program include:

**FREQUENCY:** Two to three days per week

**VOLUME:** One to three sets consisting of eight to 12 repetitions.

accessible

smooth

versatile

*it all  
starts  
with a  
vision*

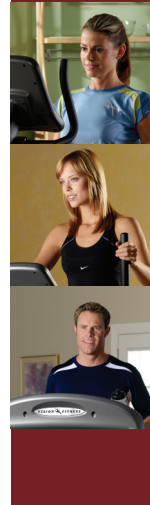

1600 Landmark Drive • Cottage Grove, WI 53527

toll free 800.335.4348 • fax 608.839.8731

[www.visionfitness.com](http://www.visionfitness.com)

©2011 Vision Fitness. All Rights Reserved. ECB-Plus, HRT, PerfectStride, Quick-Set, Quiet-Glide, SPRINT 8, and Suspension Elliptical are Trademarks of Vision Fitness. May be covered by one or more patents or patents pending: US 5540637, US 5573480, US 5813949, US 5924962, US 5938567, US 6135927, US 6149551, TW 364373, TW 371899, CN 99808486.7

12.21  
REV1